

# Case / IH 18 Spindle Picker Bar Assembly

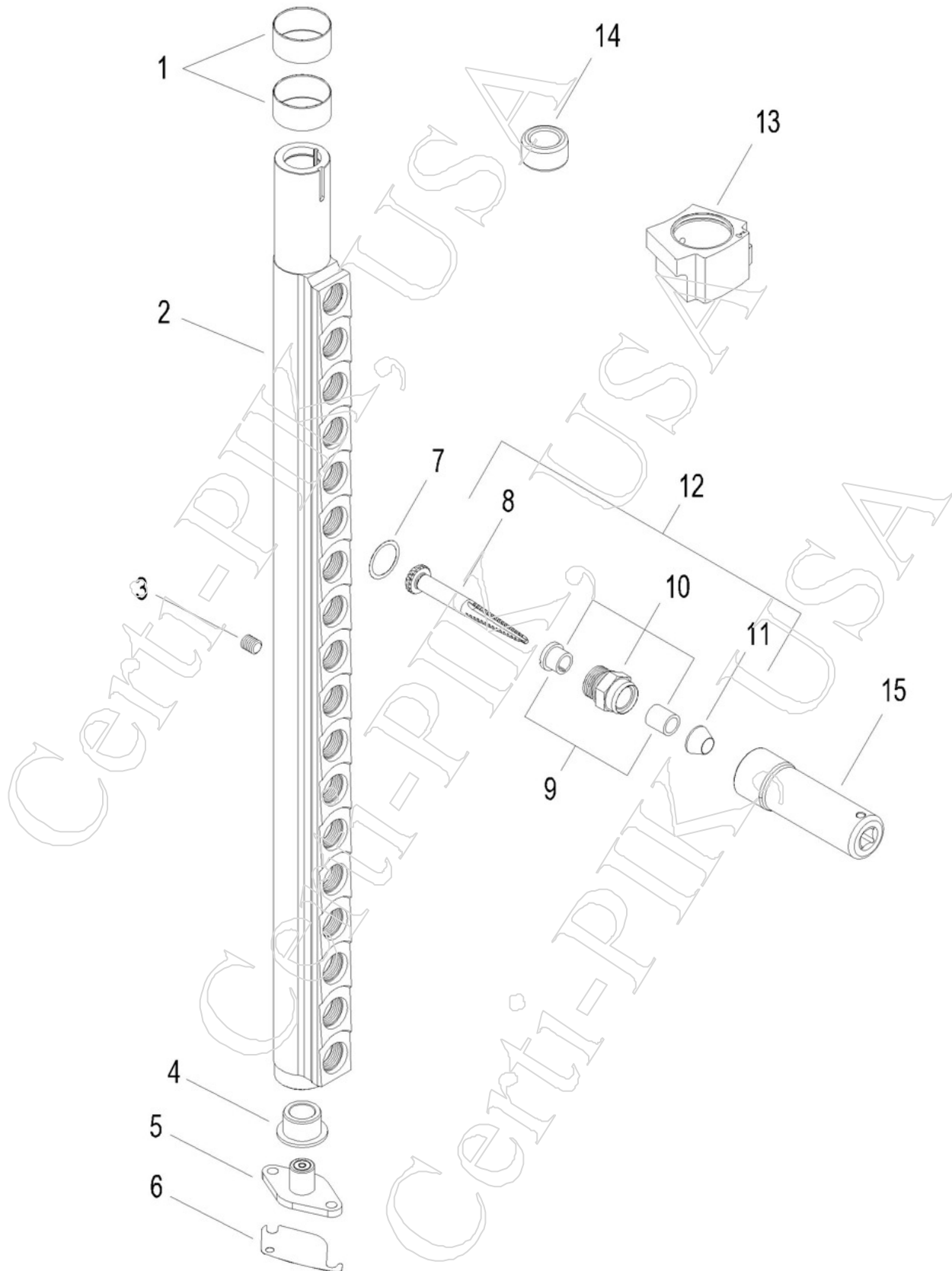

**Case / IH 18 Spindle Picker Bar Assembly**

80-1

<b>Item</b>	<b>Part</b>	<b>OEMPart</b>	<b>Qty</b>	<b>Desc</b>
1	23634C1	223634C1	2	SLEEVE - PICKER BAR (2/BAR)
2.1	82393C1R	1982393C1	1	BAR - R.H. UNIVERSAL 1800 & 2000-635 SERIES, 18 SPINDLE WITH SLEEVES
2.2	82392C1L	1982392C1	1	BAR - L.H. UNIVERSAL 1800 & 2000-635 SERIES, 18 SPINDLE WITH SLEEVES
3	00558P	<-----OEM	1	PLUG - 1/8 PIPE PLUG
4	69815R3P	669815R3	1	BUSHING - BOTTOM BAR BUSHING (1822-635)
5	14910C2P	214910C2	1	STOOL - BAR STOOL PIVOT (1822-635)
6.1	69817R1P	669817R1P	1	SHIM - .003 BAR STOOL (USE PT. NO. 93694P)(1822-635)
6.2	69818R1P	669818R1P	1	SHIM - .005 BAR STOOL (USE PT. NO. 90952P)(1822-635)
6.3	69819R1P	669819R1P	1	SHIM - .007 BAR STOOL (1822-635)
6.4	69820R1P	669820R1P	1	SHIM - .010 BAR STOOL (USE PT. NO. 90953P)(1822-635)
7	10223P	N110223	AR	SHIM - .010" SPINDLE NUT - (REPLACES CASE/IH #674980R2)
8.1	46042A1P	346042A1	18	SPINDLE R.H. CASE/IH 90 M
8.2	46041A1P	346041A1	18	SPINDLE L.H. CASE/IH 90 M
9.1	16553C1P	216553C1	18	BUSHING - SPIN. FLANGED (1822, 1844, 2022, 2044, 2055)
9.2	16552C1P	216552C1	18	BUSHING - SPIN. STRAIGHT (1822, 1844, 2022, 2044, 2055)
9.3	94863C1P	1994863C1	18	CASE SPINDLE BUSHING STRAIGHT (NEW STYLE - SMALLER DIA): USED IN #94866C1 & #94865C1 NUT ASSYS -(2055-635)
9.4	94864C1P	1994864C1	18	CASE SPINDLE BUSHING FLANGED (NEW STYLE - SMALLER DIA): USED IN #94866C1 & #94865C1 NUT ASSYS -(2055-635)
10.1	64768A1	364768A1	18	ASSEMBLY - R.H. SPINDLE NUT WITH PRESSED BUSHINGS - USES NEW BUSHINGS #94864C1P & #94863C1P
10.2	64767A1	364767A1	18	ASSEMBLY - L.H. SPINDLE NUT WITH PRESSED BUSHINGS - USES NEW BUSHINGS #94864C1P & #94863C1P
11	16554C1P	216554C1	18	DUST CAP - SPINDLE
12.1	64348A1	364348A1	18	ASSEMBLY - R.H. PRE-ASSEMBLED SPINDLE PARTS - 90M
12.2	64347A1	364347A1	18	ASSEMBLY - L.H. PRE-ASSEMBLED SPINDLE PARTS - 90M
13	82394C2	1982394C2	1	CASE - BEARING - BAR JOURNAL - (FITS ALL 2000 SER. - 635 MOD EXP. MACHINES)
14	86948C1PRM	86948C1	1	ROLLER - CAM ROLLER - (1822-635 MOD EXP)
15	75063	N275063	1	PICKER SPINDLE SOCKET, 1-1/8 IMPACT, HARDENED, REDUCED WEIGHT, LINED WITH PLASTIC TO PROTECT BARBS